

HORIZONTAL MULTISTAGE CENTRIFUGAL ELECTRIC PUMPS

in AISI 304

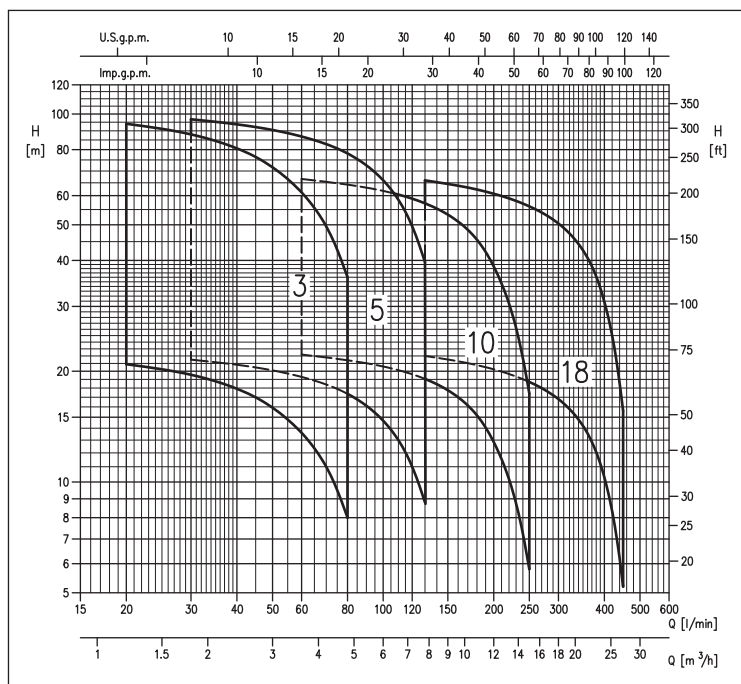

PERFORMANCE CURVES (according to ISO 9906 Attachment A)



IDENTIFICATION CODE

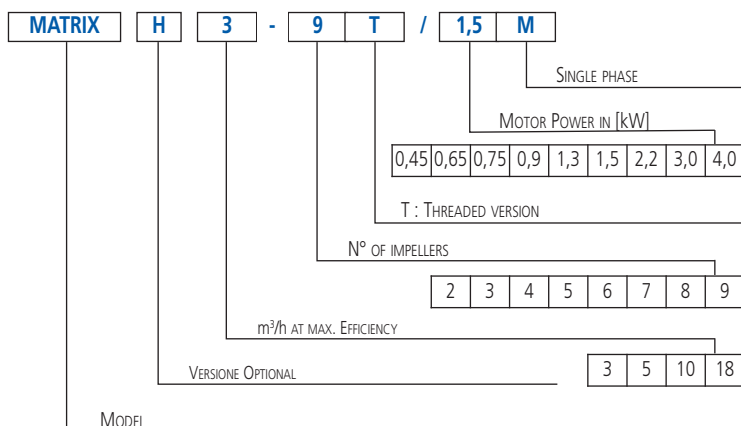

Horizontal multistage centrifugal electric pumps in AISI 304 stainless steel

APPLICATION

- Industrial washing
- Pressure boosting units
- Industrial plants
- Distribution and treatment of water
- Heating and air conditioning
- Cooling and chiller
- Irrigation
- Recovery of rain water

TECHNICAL DETAILS

- Strong and compact construction
- Available in various versions and models
- WRAS approval for the standard version (up to +85°C)

PUMP TECHNICAL DATA

Temperature of the liquid:
from -15°C to +85°C (standard)
from -15°C to +110°C (for TE version for high temperature)

- Maximum working pressure: 10 bar
- Maximum chlorine content: 500 ppm
- G1 suction connection for MATRIX 3, G1¼ for MATRIX 5, G1½ for MATRIX 10, G2 for MATRIX 18
- G1 discharge connection for MATRIX 3-5, G1¼ for MATRIX 10, G1½ for MATRIX 18

MOTOR TECHNICAL DATA

- High efficiency motors IE2 starting from 0,75kW
- Self-ventilated 2 poles asynchronous motor
- Class of insulation F
- IP55 Protection degree
- 230V ±10%, 50Hz single phase voltage
230/400V±10%, 50Hz three phase voltage
- Permanent capacitor inserted and thermo-amperometric protection with automatic rearm incorporated for the single phase motor
- Protection under user's responsibility for the three phase version

MATERIALS

- Pump casing, impellers, intermediate stages, seal housing disc and shaft (part in contact with the liquid) in EN 1.4301 (AISI 304)
- Mechanical seal in Carbon/Ceramic/EPDM
- Bracket in EN AB-AISI11Cu2(Fe) (microcasted aluminium)
- Pump casing, impellers, intermediate stages, seal housing disc and shaft (part in contact with the liquid) in AISI 304
- Mechanical sealing in Carbon/Ceramic/EPDM
- Support and motor casing in aluminium

CONTROL PANELS

- 1EPBH

ACCESSORIES (on request)

- 5 litre 10 bar ¾ EPDM vessel
- 24 litre 8 bar 1" EPDM vessel
- 24 litre 10 bar 1" EPDM vessel
- 24 litre 16 bar 1" EPDM vessel
- PVC 5m key float with counter-weight
- PVC 10m key float with counter-weight
- SQUARE-D FSG-2 1.4÷4.6 bar G¼ F pressure switch
- FYG-22 2.8÷7 bar G¼ F pressure switch
- FYG-32 5.6÷10.5 bar G¼ F pressure switch
- Presscomfort - Pressure regulator
- Press•o•Matic - Variable speed control system (230V±10% power supply single phase - 220V three phase output - maximum motor power 2.2 kW - 3 HP)
- E-drive - Frequency converter



MATRIX

HORIZONTAL MULTISTAGE CENTRIFUGAL ELECTRIC PUMPS in AISI 304

PERFORMANCE CURVES serie MATRIX 3 (from 2 to 5 impellers)
(according to ISO 9906 Attachment A)

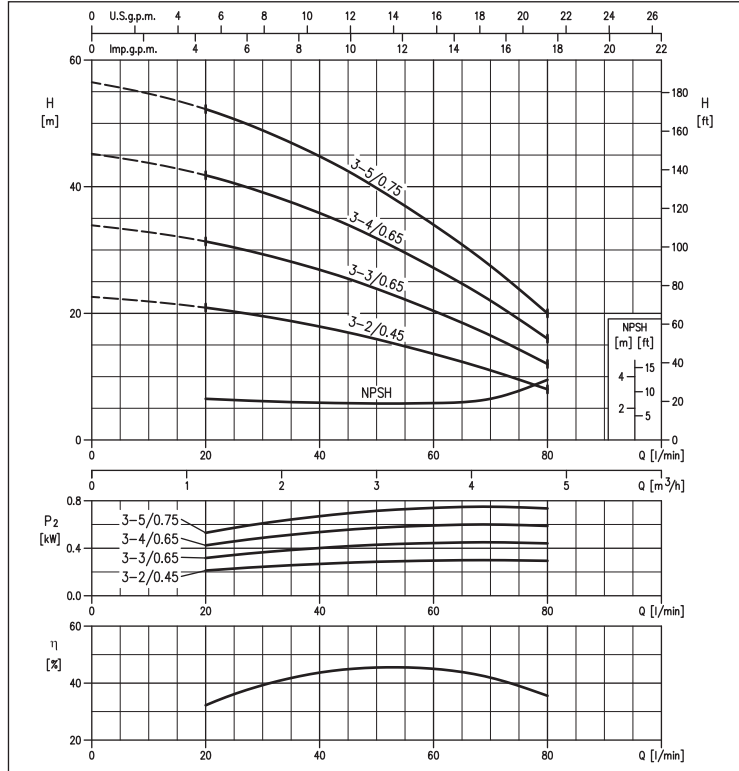

PERFORMANCE CURVES serie MATRIX 3 (from 6 to 9 impellers)
(according to ISO 9906 Attachment A)

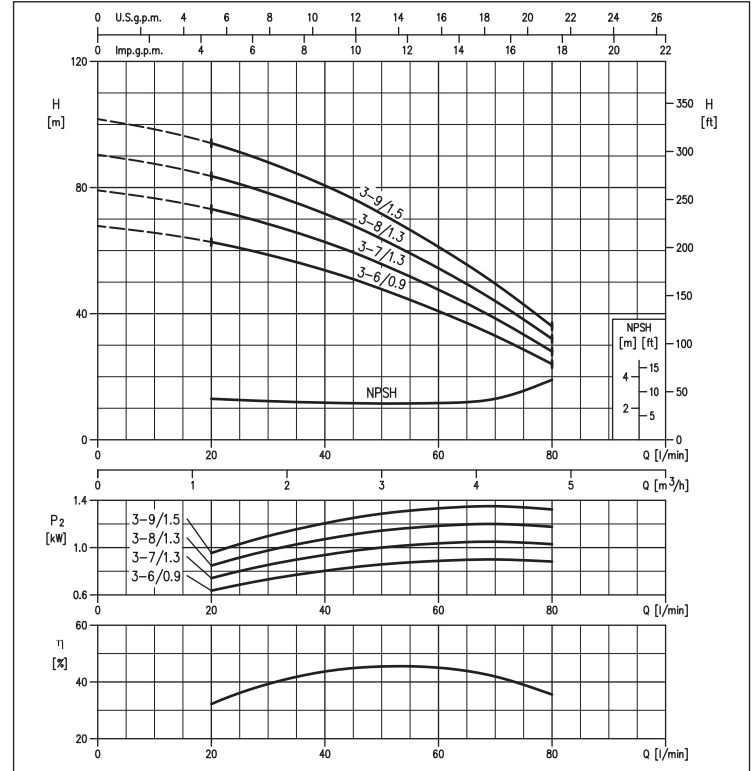

PERFORMANCE CURVES serie MATRIX 5 (from 2 to 5 impellers)
(according to ISO 9906 Attachment A)

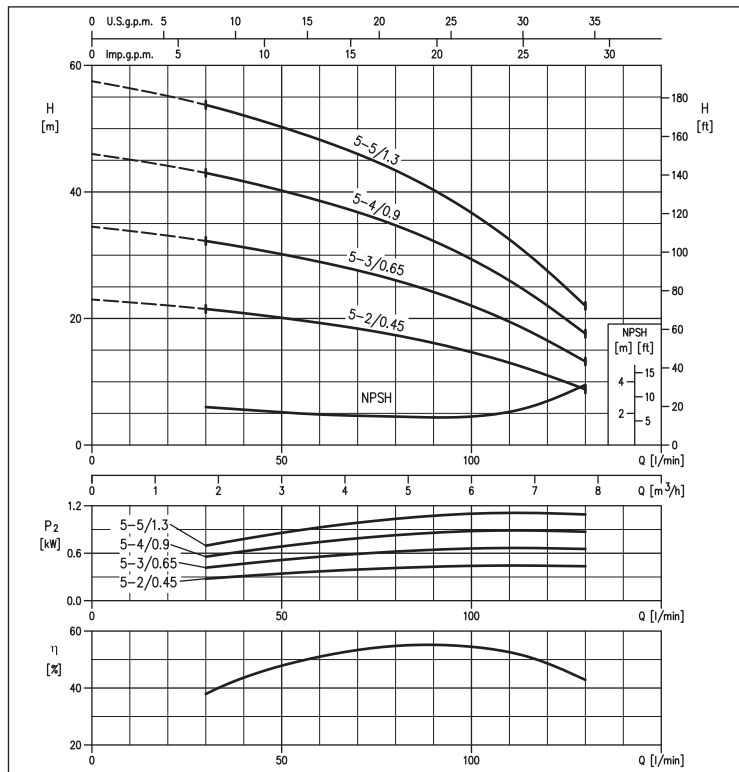

PERFORMANCE CURVES serie MATRIX 5 (from 6 to 9 impellers)
(according to ISO 9906 Attachment A)

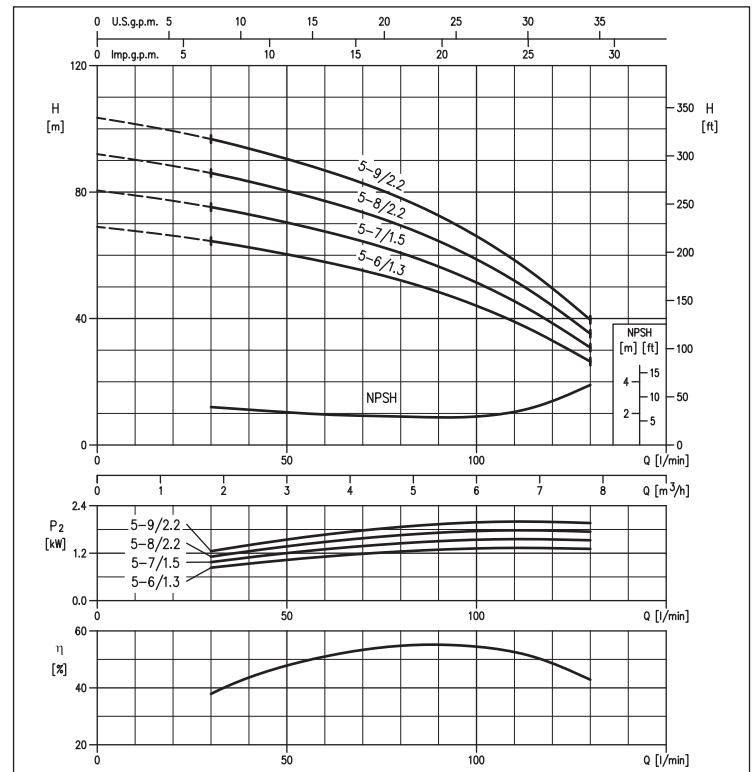



MATRIX

HORIZONTAL MULTISTAGE CENTRIFUGAL ELECTRIC PUMPS

in AISI 304

PERFORMANCE CURVES serie MATRIX 10 (from 2 to 4 impellers)
(according to ISO 9906 Attachment A)

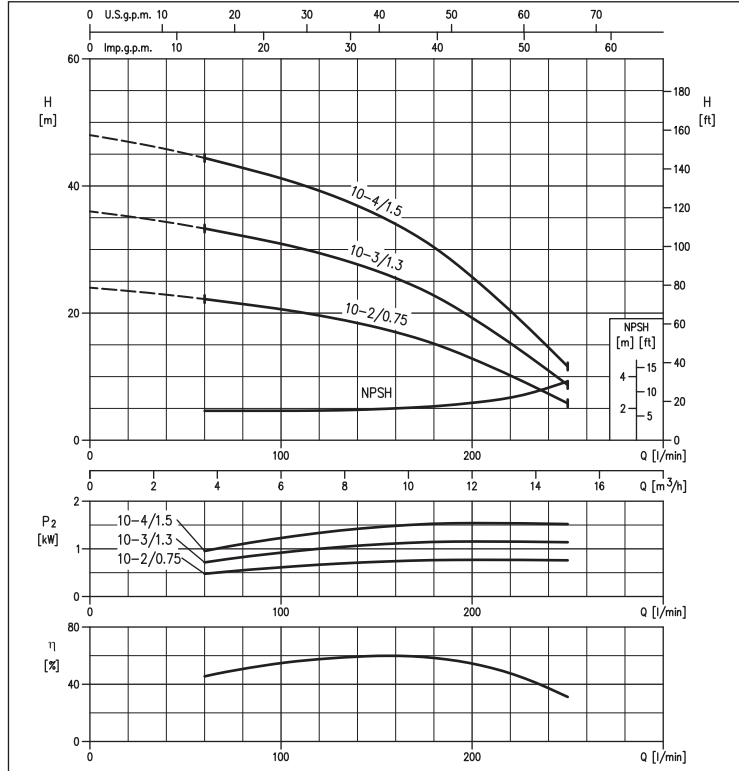

PERFORMANCE CURVES serie MATRIX 10 (5 e 6 impellers)
(according to ISO 9906 Attachment A)

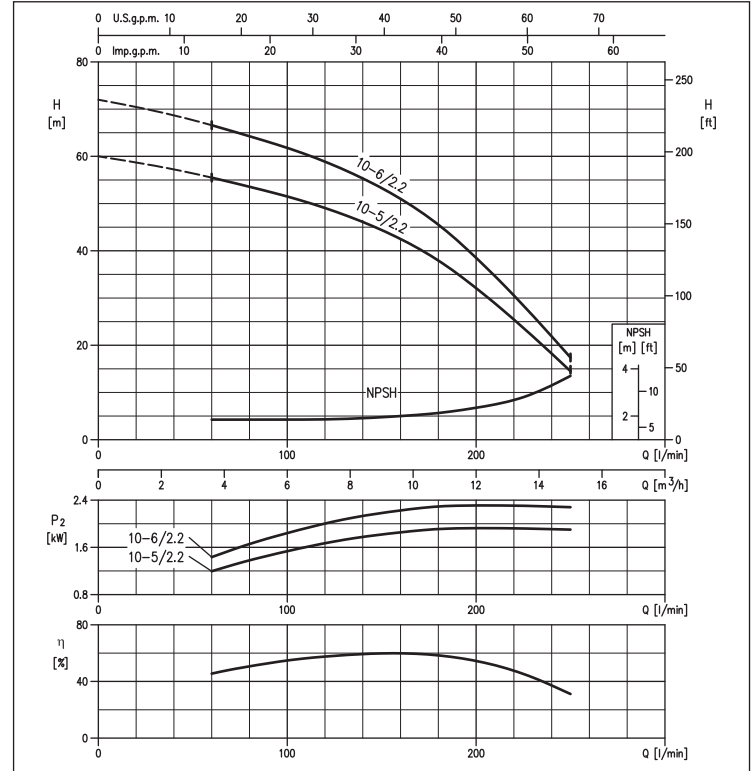

PERFORMANCE CURVES serie MATRIX 18 (from 2 to 4 impellers)
(according to ISO 9906 Attachment A)

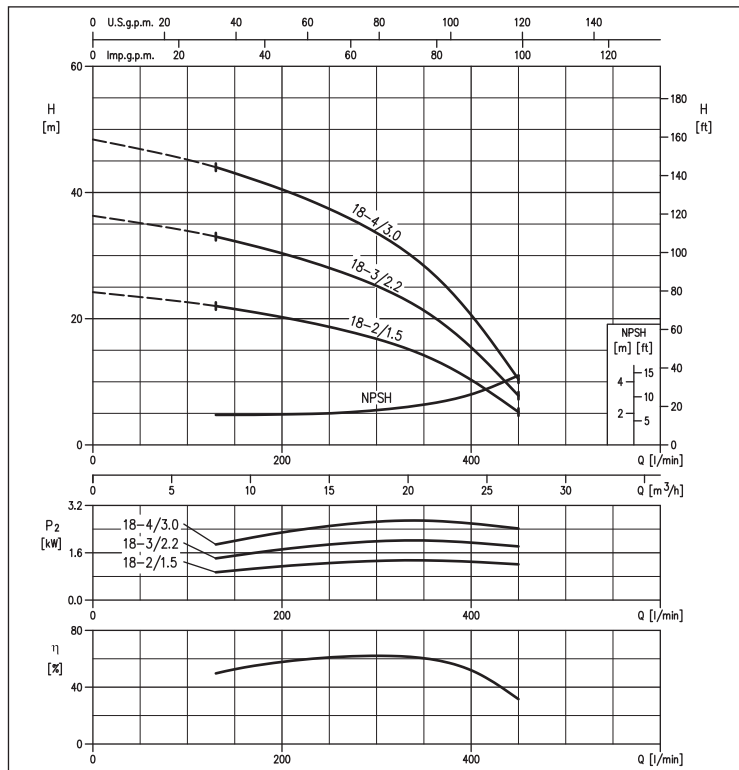

PERFORMANCE CURVES serie MATRIX 18 (5 e 6 impellers)
(according to ISO 9906 Attachment A)

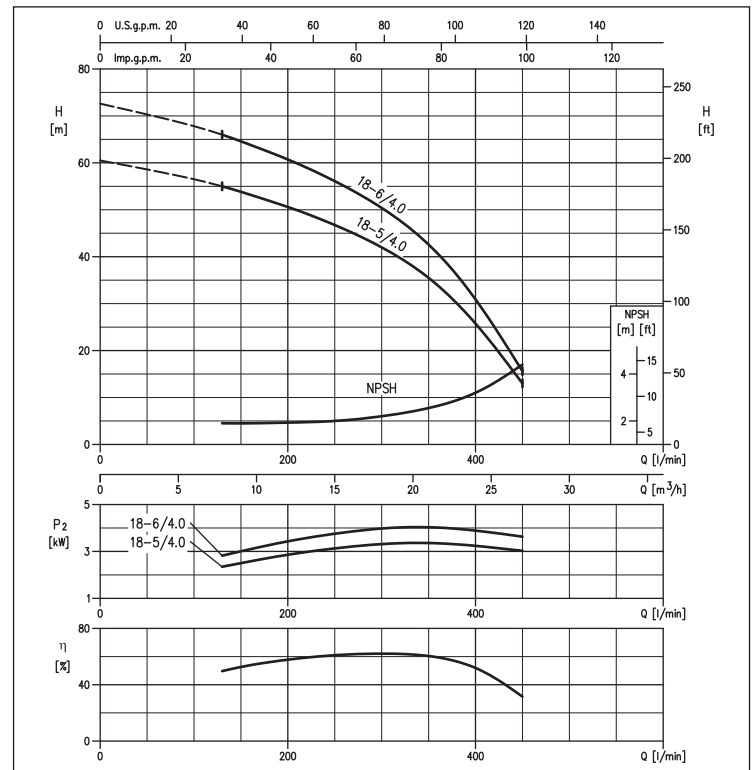

The contents of this publication must not be regarded as binding. EBARA Pumps Europe S.p.A. reserves the right to effect any modification it deems necessary without prior notice.

HORIZONTAL MULTISTAGE CENTRIFUGAL ELECTRIC PUMPS

in AISI 304

PERFORMANCE TABLE

Single phase 230V	Model	Three phase 230/400V	P ₂		Q=Flow rate															
			[HP]	[kW]	l/min	20	30	45	60	80	100	130	160	200	250	300	350	400	450	
					m ³ /h	1,2	1,8	2,7	3,6	4,8	6	7,8	9,6	12	15	18	21	24	27	
					H=Head [m]															
MATRIX 3-2T/0.45M	MATRIX 3-2T/0.45	MATRIX 3-2T/0.45	0,6	0,45	20,9	19,6	17,0	13,6	8,0	-	-	-	-	-	-	-	-	-	-	-
MATRIX 3-3T/0.65M	MATRIX 3-3T/0.65	MATRIX 3-3T/0.65	0,9	0,65	31,4	29,3	25,5	20,4	12,0	-	-	-	-	-	-	-	-	-	-	-
MATRIX 3-4T/0.65M	MATRIX 3-4T/0.65	MATRIX 3-4T/0.65	0,9	0,65	42,0	39,1	34,0	27,2	16,0	-	-	-	-	-	-	-	-	-	-	-
MATRIX 3-5T/0.75M	MATRIX 3-5T/0.75	MATRIX 3-5T/0.75	1	0,75	52,5	49,0	42,5	34,0	20,0	-	-	-	-	-	-	-	-	-	-	-
MATRIX 3-6T/0.9M	MATRIX 3-6T/0.9	MATRIX 3-6T/0.9	1,2	0,9	62,5	58,5	51,0	41,0	24,0	-	-	-	-	-	-	-	-	-	-	-
MATRIX 3-7T/1.3M	MATRIX 3-7T/1.3	MATRIX 3-7T/1.3	1,8	1,3	73,0	68,5	59,5	47,5	28,0	-	-	-	-	-	-	-	-	-	-	-
MATRIX 3-8T/1.3M	MATRIX 3-8T/1.3	MATRIX 3-8T/1.3	1,8	1,3	83,5	78,0	68,0	54,5	32,0	-	-	-	-	-	-	-	-	-	-	-
MATRIX 3-9T/1.5M	MATRIX 3-9T/1.5	MATRIX 3-9T/1.5	2	1,5	94,0	88,0	76,5	61,0	36,0	-	-	-	-	-	-	-	-	-	-	-
MATRIX 5-2T/0.45M	MATRIX 5-2T/0.45	MATRIX 5-2T/0.45	0,6	0,45	-	21,5	20,5	19,3	17,4	14,7	8,8	-	-	-	-	-	-	-	-	-
MATRIX 5-3T/0.65M	MATRIX 5-3T/0.65	MATRIX 5-3T/0.65	0,9	0,65	-	32,3	30,7	29,0	26,0	22,0	13,2	-	-	-	-	-	-	-	-	-
MATRIX 5-4T/0.9M	MATRIX 5-4T/0.9	MATRIX 5-4T/0.9	1,2	0,9	-	43,0	41,0	38,6	34,7	29,4	17,6	-	-	-	-	-	-	-	-	-
MATRIX 5-5T/1.3M	MATRIX 5-5T/1.3	MATRIX 5-5T/1.3	1,8	1,3	-	54,0	51,0	48,5	43,5	36,7	22,0	-	-	-	-	-	-	-	-	-
MATRIX 5-6T/1.3M	MATRIX 5-6T/1.3	MATRIX 5-6T/1.3	1,8	1,3	-	64,5	61,5	58,0	52,0	44,0	26,4	-	-	-	-	-	-	-	-	-
MATRIX 5-7T/1.5M	MATRIX 5-7T/1.5	MATRIX 5-7T/1.5	2	1,5	-	75,5	72,0	67,5	61,0	51,5	30,8	-	-	-	-	-	-	-	-	-
MATRIX 5-8T/2.2M	MATRIX 5-8T/2.2	MATRIX 5-8T/2.2	3	2,2	-	86,0	82,0	77,0	69,5	58,5	35,2	-	-	-	-	-	-	-	-	-
MATRIX 5-9T/2.2M	MATRIX 5-9T/2.2	MATRIX 5-9T/2.2	3	2,2	-	97,0	92,0	87,0	78,0	66,0	39,6	-	-	-	-	-	-	-	-	-
MATRIX 10-2T/0.75M	MATRIX 10-2T/0.75	MATRIX 10-2T/0.75	1	0,75	-	-	-	22,2	21,4	20,6	19,1	17,0	12,8	5,8	-	-	-	-	-	-
MATRIX 10-3T/1.3M	MATRIX 10-3T/1.3	MATRIX 10-3T/1.3	1,8	1,3	-	-	-	33,3	32,1	30,9	28,6	25,5	19,3	8,7	-	-	-	-	-	-
MATRIX 10-4T/1.5M	MATRIX 10-4T/1.5	MATRIX 10-4T/1.5	2	1,5	-	-	-	44,5	43,0	41,0	38,1	34,0	25,7	11,6	-	-	-	-	-	-
MATRIX 10-5T/2.2M	MATRIX 10-5T/2.2	MATRIX 10-5T/2.2	3	2,2	-	-	-	55,5	53,5	51,5	47,5	42,5	32,1	14,5	-	-	-	-	-	-
MATRIX 10-6T/2.2M	MATRIX 10-6T/2.2	MATRIX 10-6T/2.2	3	2,2	-	-	-	66,5	64,5	62,0	57,0	51,0	38,5	17,4	-	-	-	-	-	-
MATRIX 18-2T/1.5M	MATRIX 18-2T/1.5	MATRIX 18-2T/1.5	2	1,5	-	-	-	-	-	-	22,0	21,3	20,2	18,7	16,8	14,2	10,3	5,2	-	-
MATRIX 18-3T/2.2M	MATRIX 18-3T/2.2	MATRIX 18-3T/2.2	3	2,2	-	-	-	-	-	-	33,0	31,9	30,4	28,1	25,2	21,3	15,5	7,8	-	-
	MATRIX 18-4T/3	MATRIX 18-4T/3	4	3	-	-	-	-	-	-	44,0	42,5	40,5	37,4	33,6	28,4	20,6	10,4	-	-
	MATRIX 18-5T/4	MATRIX 18-5T/4	5,5	4	-	-	-	-	-	-	55,0	53,0	50,5	47,0	42,0	35,5	25,8	13,0	-	-
	MATRIX 18-6T/4	MATRIX 18-6T/4	5,5	4	-	-	-	-	-	-	66,0	64,0	60,5	56,0	50,5	42,5	30,9	15,6	-	-

DIMENSIONS

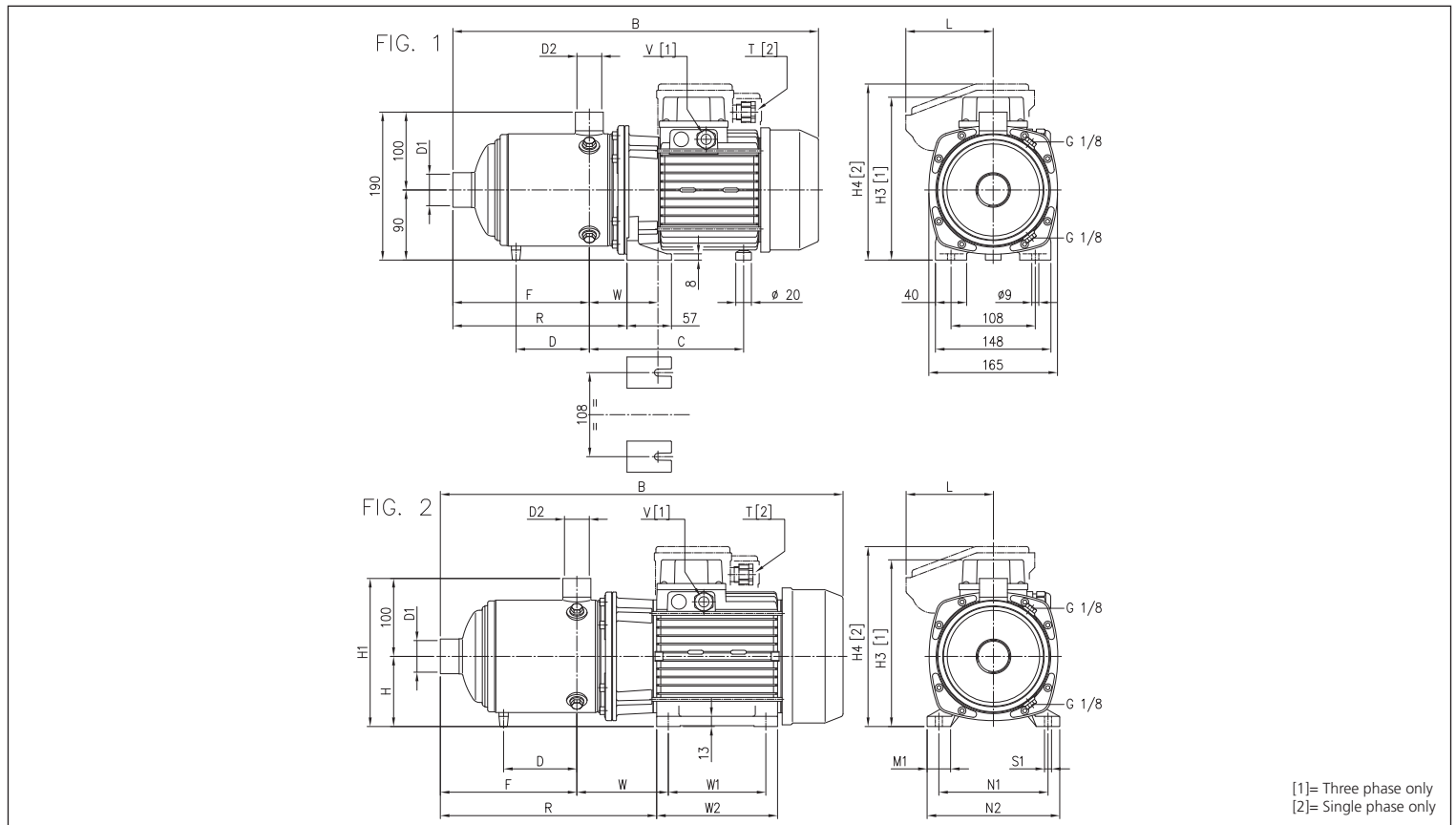

HORIZONTAL MULTISTAGE CENTRIFUGAL ELECTRIC PUMPS

in AISI 304

MATRIX 3 DIMENSIONS TABLE

Model	Fig.	Dimensions [mm]														Weight [kg]
		B	C	D	F	H3 [1]	H4 [2]	L	R	T [2]	V [1]	W	D1	D2		
MATRIX 3-2T/0,45M	1	360	171	-	103	-	200	86,5	151,5	PG11	-	88÷97	1"	1"	8,5	
MATRIX 3-2T/0,45	1	360	171	-	103	192	-	-	151,5	-	PG11	88÷97	1"	1"	8,4	
MATRIX 3-3T/0,65M	1	360	171	-	103	-	200	86,5	151,5	PG11	-	88÷97	1"	1"	9,9	
MATRIX 3-3T/0,65	1	360	171	-	103	192	-	-	151,5	-	PG11	88÷97	1"	1"	9,8	
MATRIX 3-4T/0,65M	1	384	171	-	127	-	200	86,5	175,5	PG11	-	88÷97	1"	1"	10,6	
MATRIX 3-4T/0,65	1	384	171	-	127	192	-	-	175,5	-	PG11	88÷97	1"	1"	10,4	
MATRIX 3-5T/0,75M	1	408	171	-	151	-	200	86,5	199,5	PG11	-	88÷97	1"	1"	12,5	
MATRIX 3-5T/0,75	1	408	171	-	151	192	-	-	199,5	-	PG11	88÷97	1"	1"	12,4	
MATRIX 3-6T/0,9M	1	432	171	-	175	-	219	106	223,5	M20x1,5	-	88÷97	1"	1"	13,7	
MATRIX 3-6T/0,9	1	444	171	-	175	192	-	-	223,5	-	PG11	88÷97	1"	1"	13,6	
MATRIX 3-7T/1,3M	1	493	198	110,5	199	-	226	112	247,5	M20x1,5	-	88÷97	1"	1"	16,3	
MATRIX 3-7T/1,3	1	493	198	110,5	199	209	-	-	247,5	-	PG11	88÷97	1"	1"	17,0	
MATRIX 3-8T/1,3M	1	517	198	134,5	223	-	226	112	271,5	M20x1,5	-	88÷97	1"	1"	16,3	
MATRIX 3-8T/1,3	1	517	198	134,5	223	209	-	-	271,5	-	PG11	88÷97	1"	1"	17,8	
MATRIX 3-9T/1,5M	1	541	198	158,5	247	-	226	112	295,5	M20x1,5	-	88÷97	1"	1"	18,3	
MATRIX 3-9T/1,5	1	554	198	158,5	247	209	-	-	295,5	-	PG11	88÷97	1"	1"	20,0	

[1]= Three phase only
[2]= Single phase only

MATRIX 5-10-18 DIMENSIONS TABLE

Model	Fig.	Dimensions [mm]																				Weight [kg]		
		B	C	D	F	H	H1	H3 [1]	H4 [2]	L	R	T [2]	V [1]	W	W1	W2	M1	N1	N2	S1	D1		D2	
MATRIX 5-2T/0.45 M	1	360	171	-	103	-	-	-	200	86,5	151,5	PG11	-	88÷97	-	-	-	-	-	-	-	1"¼	1"	8,5
MATRIX 5-2T/0.45	1	360	171	-	103	-	-	192	-	-	151,5	-	PG11	88÷97	-	-	-	-	-	-	-	1"¼	1"	8,4
MATRIX 5-3T/0.65 M	1	360	171	-	103	-	-	-	200	86,5	151,5	PG11	-	88÷97	-	-	-	-	-	-	-	1"¼	1"	9,9
MATRIX 5-3T/0.65	1	360	171	-	103	-	-	192	-	-	151,5	-	PG11	88÷97	-	-	-	-	-	-	-	1"¼	1"	9,8
MATRIX 5-4T/0.9 M	1	384	171	-	127	-	-	-	219	106	175,5	M20x1,5	-	88÷97	-	-	-	-	-	-	-	1"¼	1"	12,2
MATRIX 5-4T/0.9	1	396	171	-	127	-	-	192	-	-	175,5	-	PG11	88÷97	-	-	-	-	-	-	-	1"¼	1"	12,4
MATRIX 5-5T/1.3 M	1	445	198	-	151	-	-	-	226	112	199,5	M20x1,5	-	88÷97	-	-	-	-	-	-	-	1"¼	1"	15,8
MATRIX 5-5T/1.3	1	445	198	-	151	-	-	209	-	-	199,5	-	PG11	88÷97	-	-	-	-	-	-	-	1"¼	1"	15,8
MATRIX 5-6T/1.3 M	1	469	198	-	175	-	-	-	226	112	223,5	M20x1,5	-	88÷97	-	-	-	-	-	-	-	1"¼	1"	15,2
MATRIX 5-6T/1.3	1	469	198	-	175	-	-	209	-	-	223,5	-	PG11	88÷97	-	-	-	-	-	-	-	1"¼	1"	16,2
MATRIX 5-7T/1.5 M	1	493	198	110,5	199	-	-	-	226	112	247,5	M20x1,5	-	88÷97	-	-	-	-	-	-	-	1"¼	1"	18,3
MATRIX 5-7T/1.5	1	506	198	110,5	199	-	-	209	-	-	247,5	-	PG11	88÷97	-	-	-	-	-	-	-	1"¼	1"	18,7
MATRIX 5-8T/2.2 M	2	565	-	134,5	223	90	190	-	231	112	325,5	M20x1,5	-	117,5	125	155	30	140	170	9	1"¼	1"	22,3	
MATRIX 5-8T/2.2	1	530	198	134,5	223	-	-	209	-	-	271,5	-	PG11	88÷97	-	-	-	-	-	-	-	1"¼	1"	18,7
MATRIX 5-9T/2.2 M	2	589	-	158,5	247	90	190	-	231	112	349,5	M20x1,5	-	117,5	125	155	30	140	170	9	1"¼	1"	23,3	
MATRIX 5-9T/2.2	1	554	198	158,5	247	-	-	209	-	-	295,5	-	PG11	88÷97	-	-	-	-	-	-	-	1"¼	1"	18,8
MATRIX 10-2T/0.75 M	1	379	175	-	118	-	-	-	200	86,5	170,5	PG11	-	92÷101	-	-	-	-	-	-	-	1"½	1"¼	11,3
MATRIX 10-2T/0.75	1	379	175	-	118	-	-	192	-	-	170,5	-	PG11	92÷101	-	-	-	-	-	-	-	1"½	1"¼	11,2
MATRIX 10-3T/1.3 M	1	416	202	-	118	-	-	-	226	112	170,5	M20x1,5	-	92÷101	-	-	-	-	-	-	-	1"½	1"¼	14,3
MATRIX 10-3T/1.3	1	416	202	-	118	-	-	209	-	-	170,5	-	PG11	92÷101	-	-	-	-	-	-	-	1"½	1"¼	13,6
MATRIX 10-4T/1.5 M	1	446	202	-	148	-	-	-	226	112	200,5	M20x1,5	-	92÷101	-	-	-	-	-	-	-	1"½	1"¼	15,6
MATRIX 10-4T/1.5	1	459	202	-	148	-	-	209	-	-	200,5	-	PG11	92÷101	-	-	-	-	-	-	-	1"½	1"¼	17,3
MATRIX 10-5T/2.2 M	2	524	-	-	178	90	190	-	231	112	284,5	M20x1,5	-	121,5	125	155	30	140	170	9	1"½	1"¼	21,8	
MATRIX 10-5T/2.2	1	489	202	-	178	-	-	209	-	-	230,5	-	PG11	92÷101	-	-	-	-	-	-	-	1"½	1"¼	17,9
MATRIX 10-6T/2.2 M	2	554	-	118,5	208	90	190	-	231	112	314,5	M20x1,5	-	121,5	125	155	30	140	170	9	1"½	1"¼	22,1	
MATRIX 10-6T/2.2	1	519	202	118,5	208	-	-	209	-	-	260,5	-	PG11	92÷101	-	-	-	-	-	-	-	1"½	1"¼	18,3
MATRIX 18-2T/1.5M	1	442	205	-	141	-	-	-	226	112	196,5	M20x1,5	-	95 ÷ 104	-	-	-	-	-	-	-	2"	1"½	14,5
MATRIX 18-2T/1.5M	1	455	205	-	141	-	-	209	-	-	196,5	-	PG11	95 ÷ 104	-	-	-	-	-	-	-	2"	1"½	16,2
MATRIX 18-3T/2.2M	2	490	-	-	141	90	190	-	231	112	250,5	M20x1,5	-	124,5	125	155	30	140	170	9	2"	1"½	20,7	
MATRIX 18-3T/2.2	1	455	205	-	141	-	-	209	-	-	196,5	-	PG11	95 ÷ 104	-	-	-	-	-	-	-	2"	1"½	17,2
MATRIX 18-4T/3	2	565	-	-	178,5	90	190	214	-	-	288	-	PG13,5	124,5	125	155	30	140	170	9	2"	1"½	23,8	
MATRIX 18-5T/4	2	615	-	123	216	100	200	241	-	-	315	-	PG13,5	124,5	140	170	35	160	192	11	2"	1"½	33,2	
MATRIX 18-6T/4	2	652	-	160,5	253,5	100	200	241	-	-	352,5	-	PG13,5	124,5	140	170	35	160	192	11	2"	1"½	34,2	

[1]= Three phase only
[2]= Single phase only

HORIZONTAL MULTISTAGE CENTRIFUGAL ELECTRIC PUMPS

in AISI 304

MATRIX 3-5-10 SECTIONAL VIEW

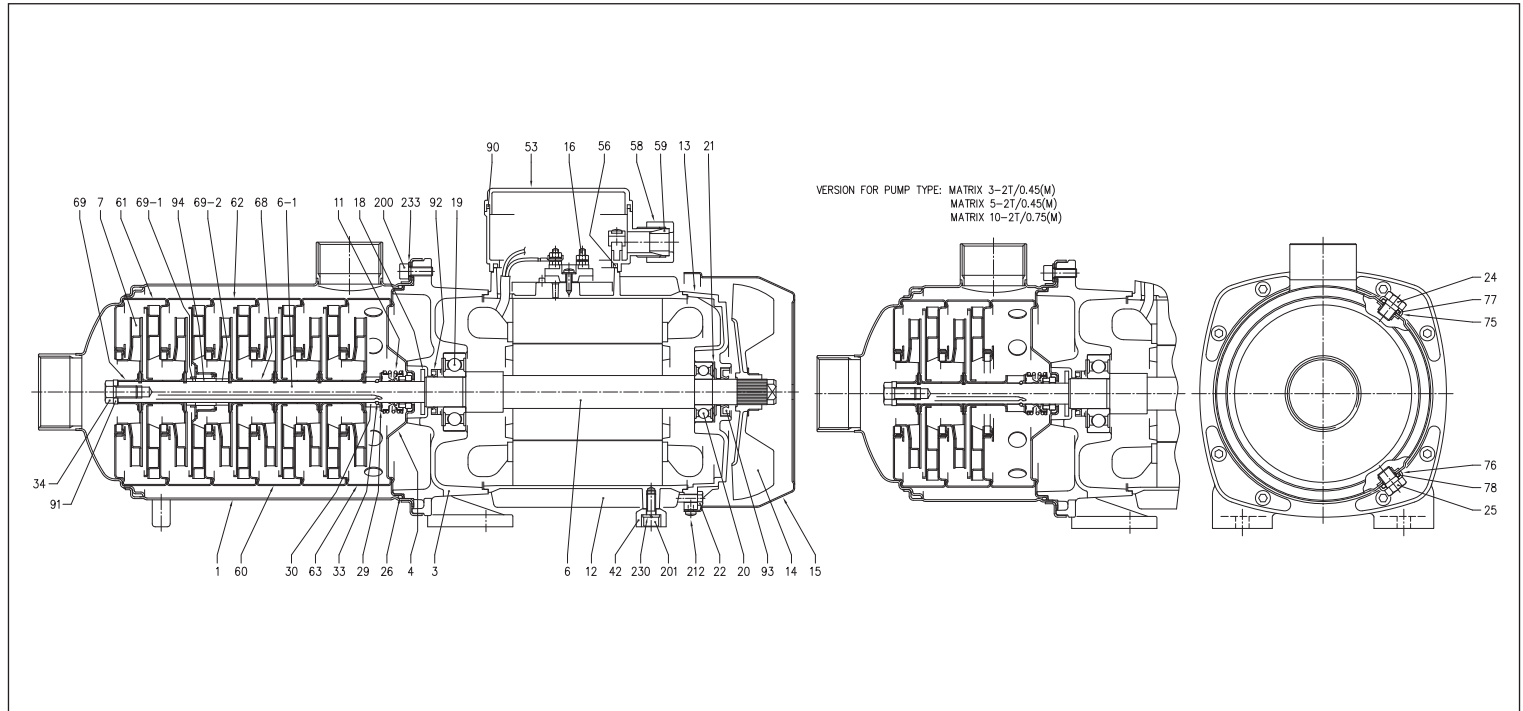

MATRIX 18 SECTIONAL VIEW

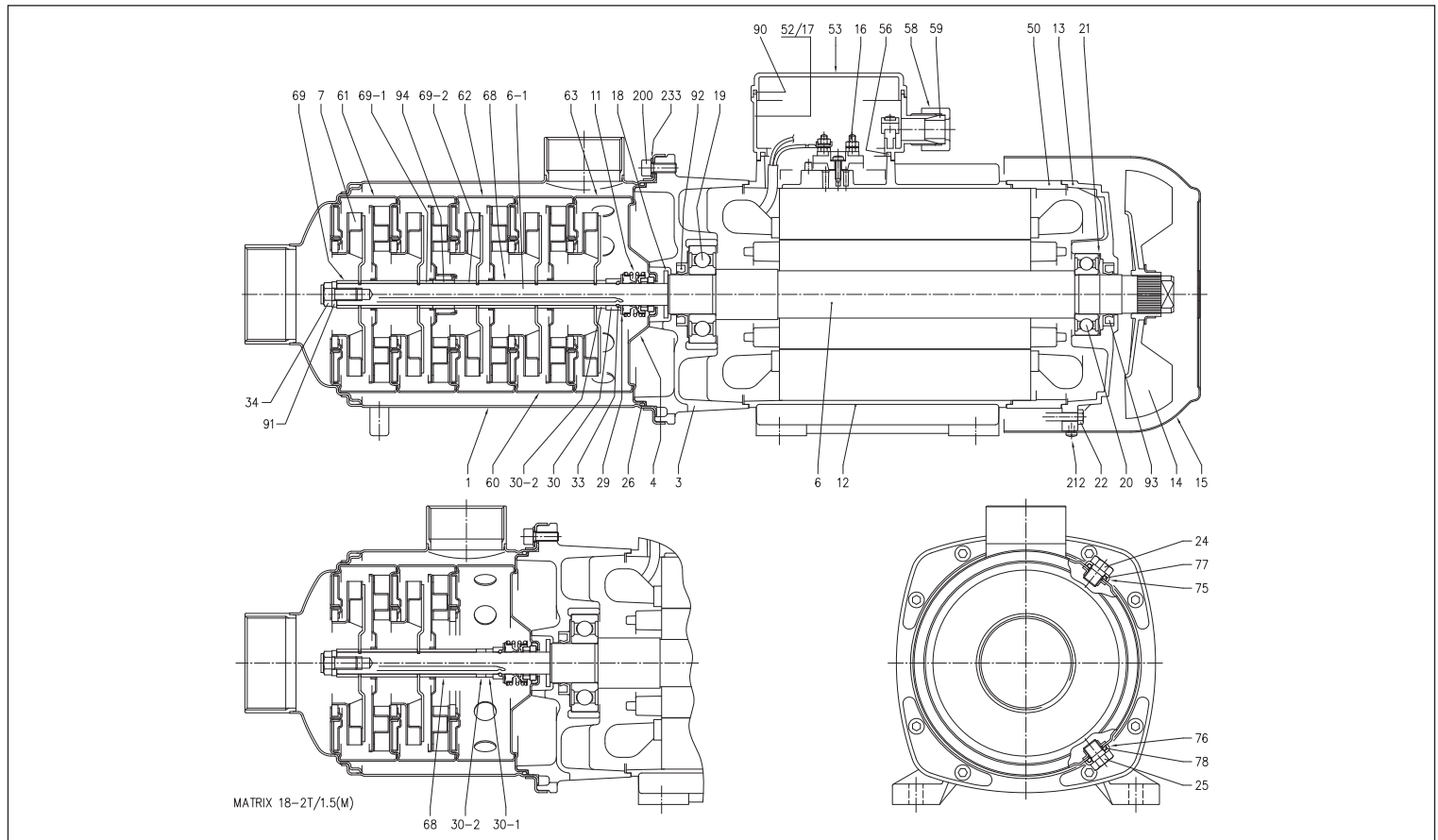

The contents of this publication must not be regarded as binding. EBARA Pumps Europe S.p.A. reserves the right to effect any modification it deems necessary, without prior notice.

HORIZONTAL MULTISTAGE CENTRIFUGAL ELECTRIC PUMPS

in AISI 304

MATERIALS TABLE

Ref.	Name	Material	Ref.	Name	Material
1	Pump body	EN 1.4301 (AISI 304)	42	Foot	Aluminium
3	Motor support	EN AB-AISI11Cu2(Fe)	50	Motore spacer [2]	Aluminium
4	Seal housing disc	EN 1.4301 (AISI 304)	52	Capacitor-holder box [1]	ABS
6	Rotor shaft	-	53	Capacitor-holder box cover [1]	ABS
6-1	Pump shaft	EN 1.4301 (AISI 304)	56	Box gasket	NBR
7	Impeller	EN 1.4301 (AISI 304)	58	Nut ring	-
11	Mechanical seal	Ceramic/Carbon/EPDM	59	Conic gasket	NBR
12	Motor case	-	60	Intermediate stage	EN 1.4301 (AISI 304)+PTFE
13	Motor cover	Aluminium	61	Intermediate stage (suction)	EN 1.4301 (AISI 304)+PTFE
14	Fan	PA	62	Intermediate stage (bearing)	EN 1.4301 (AISI 304) + PTFE + Ceramic
15	Fan cover	Galvanised Fe P04	63	Intermediate stage (discharge)	EN 1.4301 (AISI 304) + PTFE
16	Terminal box	-	68	Shaft casing (intermediate)	EN 1.4301 (AISI 304)
17	Terminal box cover	Aluminium	69	Impeller spacer	EN 1.4301 (AISI 304)
18	Spray protector ring	NBR	69-1	Shaft casing (adapter)	EN 1.4301 (AISI 304)
19	Bearing (pump side)	-	69-2	Shaft casing (adapter)	EN 1.4301 (AISI 304)
20	Bearing (motor side)	-	75	Washer	EN 1.4301 (AISI 304)
21	Adjusting ring	Steel C70	76	Washer	EN 1.4301 (AISI 304)
22	Tie-rod	Galvanised Fe 42	77	O-Ring	EPDM
24	Filler cap	EN 1.4301 (AISI 304)	78	O-Ring	EPDM
25	Drain plug	EN 1.4301 (AISI 304)	90	Terminal box cover [1]	NBR
26	O-Ring	EPDM	91	Shaft washer	EN 1.4301 (AISI 304)
29	Washer	EN 1.4301 (AISI 304)	92	Sealing ring	-
30	Holder ring	EN 1.4301 (AISI 304)	93	Sealing ring	-
30-1/2	Shaft casing	EN 1.4301 (AISI 304)	94	Guide bush	WC - Tungsten carbide
33	Ring	EN 1.4301 (AISI 304)	200	Screw (Pump body)	EN 1.4301 (AISI 304)
34	Screw	EN 1.4301 (AISI 304)	233	Plate	EN 1.4301 (AISI 304)

[1]= Single phase only

[2]= MATRIX 18-5T/4 and MATRIX 18-6T/4 only

MECHANICAL SEAL standard

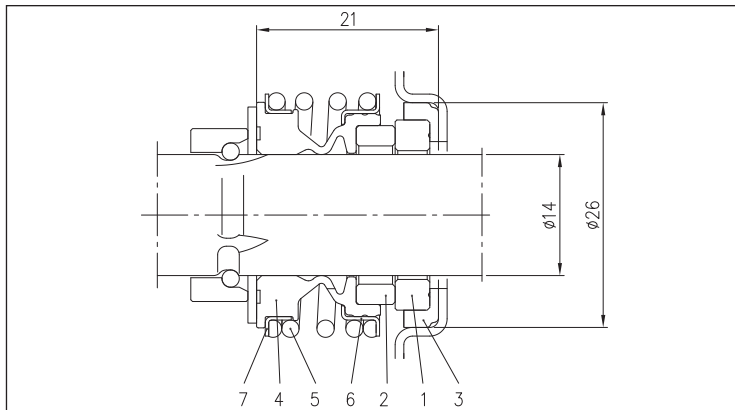

TENUTE MECCANICHE SPECIALI (a richiesta)

Ref.	Name	Material			
		Versione TE	Versione H	Versione HS	Versione U3Q1EGG
1	Fixed part	Ceramic	Carbon	SiC	Tungsten carbide
2	Rotating part	Carbon	Ceramic	SiC	SiC
3	Gasket	EPDM	FPM	FPM	EPDM
4	Diaphragm	EPDM	FPM	FPM	EPDM
5	Spring	EPDM	EN 1.4402 (AISI 316)	EN 1.4402 (AISI 316)	EN 1.4402 (AISI 316)
6	Structure/frame	EN 1.4402 (AISI 316)	EN 1.4402 (AISI 316)	EN 1.4402 (AISI 316)	EN 1.4402 (AISI 316)
7	Retainer ring	EN 1.4402 (AISI 304)	EN 1.4402 (AISI 316)	EN 1.4402 (AISI 316)	EN 1.4402 (AISI 316)

MATERIALS TABLE standard

Ref.	Name	Material
1	Fixed part	Ceramic
2	Rotating part	Carbon
3	Gasket	EPDM
4	Diaphragm	EPDM
5	Spring	EN 1.4402 (AISI 316)
6	Structure/frame	EN 1.4402 (AISI 316)
7	Retainer ring	EN 1.4402 (AISI 316)

HORIZONTAL MULTISTAGE CENTRIFUGAL ELECTRIC PUMPS

in AISI 304

ELECTRIC DATA TABLE

Model		P ₂		Efficiency		Capacitor		Efficiency			P ₁		Absorbed Current [A]		
Single phase 230V	Three phase 230/400V	[HP]	[kW]	Single phase	Three phase	Single phase μF	Three phase V _c	Three phase η %			Single phase [kW]	Three phase [kW]	Single phase 230V	Three phase 230V 400V	
								50%	75%	100%					
MATRIX 3-2T/0.45M	MATRIX 3-2T/0.45	0,6	0,45	-	-	12,5	450	-	-	-	0,73	0,72	3,2	2,3	1,3
MATRIX 3-3T/0.65M	MATRIX 3-3T/0.65	0,9	0,65	-	-	16	450	-	-	-	0,97	0,85	4,5	2,8	1,6
MATRIX 3-4T/0.65M	MATRIX 3-4T/0.65	0,9	0,65	-	-	16	450	-	-	-	0,97	0,85	4,5	2,8	1,6
MATRIX 3-5T/0.75M	MATRIX 3-5T/0.75	1,0	0,75	-	IE2	25	450	77,2	80,9	81,3	1,14	0,92	5,4	3,0	1,7
MATRIX 3-6T/0.9M	MATRIX 3-6T/0.9	1,2	0,9	-	IE2	31,5	450	79,0	81,7	81,6	1,28	1,35	5,7	4,3	2,5
MATRIX 3-7T/1.3M	MATRIX 3-7T/1.3	1,8	1,3	-	IE2	35	450	79,7	82,5	83,0	1,75	1,80	7,8	5,6	3,2
MATRIX 3-8T/1.3M	MATRIX 3-8T/1.3	1,8	1,3	-	IE2	35	450	79,7	82,5	83,0	1,75	1,80	7,8	5,6	3,2
MATRIX 3-9T/1.5M	MATRIX 3-9T/1.5	2,0	1,5	-	IE2	40	450	78,6	83,0	84,2	1,95	1,78	8,7	6,3	3,7
MATRIX 5-2T/0.45M	MATRIX 5-2T/0.45	0,6	0,45	-	-	12,5	450	-	-	-	0,73	0,72	3,2	2,3	1,3
MATRIX 5-3T/0.65M	MATRIX 5-3T/0.65	0,9	0,65	-	-	16	450	-	-	-	0,97	0,85	4,5	2,8	1,6
MATRIX 5-4T/0.9M	MATRIX 5-4T/0.9	1,2	0,9	-	IE2	31,5	450	79,0	81,7	81,6	1,28	1,35	5,7	4,3	2,5
MATRIX 5-5T/1.3M	MATRIX 5-5T/1.3	1,8	1,3	-	IE2	35	450	79,7	82,5	83,0	1,75	1,80	7,8	5,6	3,2
MATRIX 5-6T/1.3M	MATRIX 5-6T/1.3	1,8	1,3	-	IE2	35	450	79,7	82,5	83,0	1,75	1,80	7,8	5,6	3,2
MATRIX 5-7T/1.5M	MATRIX 5-7T/1.5	2,0	1,5	-	IE2	40	450	78,6	83,0	84,2	1,95	1,78	8,7	6,3	3,7
MATRIX 5-8T/2.2M	MATRIX 5-8T/2.2	3,0	2,2	-	IE2	50	450	83,0	84,4	83,8	2,92	2,63	13,0	8,2	4,7
MATRIX 5-9T/2.2M	MATRIX 5-9T/2.2	3,0	2,2	-	IE2	50	450	83,0	84,4	83,8	2,92	2,63	13,0	8,2	4,7
MATRIX 10-2T/0.75M	MATRIX 10-2T/0.75	1,0	0,75	-	IE2	25	450	77,2	80,9	81,3	1,14	0,92	5,4	3,0	1,7
MATRIX 10-3T/1.3M	MATRIX 10-3T/1.3	1,8	1,3	-	IE2	35	450	79,7	82,5	83,0	1,75	1,80	7,8	5,6	3,2
MATRIX 10-4T/1.5M	MATRIX 10-4T/1.5	2,0	1,5	-	IE2	40	450	78,6	83,0	84,2	1,95	1,78	8,7	6,3	3,7
MATRIX 10-5T/2.2M	MATRIX 10-5T/2.2	3,0	2,2	-	IE2	50	450	83,0	84,4	83,8	2,92	2,63	13,0	8,2	4,7
MATRIX 10-6T/2.2M	MATRIX 10-6T/2.2	3,0	2,2	-	IE2	50	450	83,0	84,4	83,8	2,92	2,63	13,0	8,2	4,7
MATRIX 18-2T/1.5M	MATRIX 18-2T/1.5	2,0	1,5	-	IE2	40	450	78,6	83,0	84,2	1,95	1,78	8,7	6,3	3,7
MATRIX 18-3T/2.2M	MATRIX 18-3T/2.2	3,0	2,2	-	IE2	50	450	83,0	84,4	83,8	2,92	2,63	13,0	8,2	4,7
-	MATRIX 18-4T/3	4,0	3	-	IE2	-	-	85,0	86,7	86,3	-	3,48	-	10,6	6,1
-	MATRIX 18-5T/4	5,5	4	-	IE2	-	-	84,3	87,2	87,8	-	4,56	-	15,1	8,7
-	MATRIX 18-6T/4	5,5	4	-	IE2	-	-	84,3	87,2	87,8	-	4,56	-	15,1	8,7

NOISE DATA TABLE

Model		P ₂		L _{pA} - dB(A)*
Single phase 230V	Three phase 230/400V	[HP]	[kW]	
MATRIX 3-2T/0.45M	MATRIX 3-2T/0.45	0,6	0,45	61
MATRIX 3-3T/0.65M	MATRIX 3-3T/0.65	0,9	0,65	62
MATRIX 3-4T/0.65M	MATRIX 3-4T/0.65	0,9	0,65	
MATRIX 3-5T/0.75M	MATRIX 3-5T/0.75	1,0	0,75	64
MATRIX 3-6T/0.9M	MATRIX 3-6T/0.9	1,2	0,9	
MATRIX 3-7T/1.3M	MATRIX 3-7T/1.3	1,8	1,3	64
MATRIX 3-8T/1.3M	MATRIX 3-8T/1.3	1,8	1,3	
MATRIX 3-9T/1.5M	MATRIX 3-9T/1.5	2,0	1,5	61
MATRIX 5-2T/0.45M	MATRIX 5-2T/0.45	0,6	0,45	
MATRIX 5-3T/0.65M	MATRIX 5-3T/0.65	0,9	0,65	62
MATRIX 5-4T/0.9M	MATRIX 5-4T/0.9	1,2	0,9	
MATRIX 5-5T/1.3M	MATRIX 5-5T/1.3	1,8	1,3	64
MATRIX 5-6T/1.3M	MATRIX 5-6T/1.3	1,8	1,3	
MATRIX 5-7T/1.5M	MATRIX 5-7T/1.5	2,0	1,5	65
MATRIX 5-8T/2.2M	MATRIX 5-8T/2.2	3,0	2,2	
MATRIX 5-9T/2.2M	MATRIX 5-9T/2.2	3,0	2,2	62
MATRIX 10-2T/0.75M	MATRIX 10-2T/0.75	1,0	0,75	
MATRIX 10-3T/1.3M	MATRIX 10-3T/1.3	1,8	1,3	64
MATRIX 10-4T/1.5M	MATRIX 10-4T/1.5	2,0	1,5	
MATRIX 10-5T/2.2M	MATRIX 10-5T/2.2	3,0	2,2	65
MATRIX 10-6T/2.2M	MATRIX 10-6T/2.2	3,0	2,2	
MATRIX 18-2T/1.5M	MATRIX 18-2T/1.5	2,0	1,5	64
MATRIX 18-3T/2.2M	MATRIX 18-3T/2.2	3,0	2,2	65
-	MATRIX 18-4T/3	4,0	3	68
-	MATRIX 18-5T/4	5,5	4	69
-	MATRIX 18-6T/4	5,5	4	

* Mean value of several measures at 1m distance around the pump.
Tolerance ± 2,5 dB.